

technical specification

LED strip

Over 1200 Lumens per metre LED output.
 Only 14.4 watts per metre power consumption
 75% energy saving compared to Fluorescent.
 24 volt input, less current less voltage drop.
 6000k cool white or 3000k warm white 120 degree angle.
 IP65 protected, 50,000 hours+ lamp life.
 5 year Warranty.
 Full CE certification and ROHS compliant.

Drivers

Epoxy encapsulated fully isolated case with IP67 protection.
 Constant voltage design.
 Short circuit, over current, over voltage protection.
 Fitted onto Kwik release slide in Gear Trays.
 Full CE certification and ROHS compliant.

Light Fitting

Specialist designed asymmetric optical lens offers even illumination up to 5 metres deep with minimal backspill.

Specially designed 76mm diameter aluminium extrusion supplied up to 6000mm lengths which can be joined together using cast aluminium connectors.

Die cast aluminium end caps.

Standard 300mm Kwik Fit brackets.

Casing sealed and certificated to IP64.

Full CE certificate and 5 year parts warranty.

Conforms to EN60598-2-1:1989, and BS EN 60598-1:2008 "UK Deviations Only", BS EN62471 and high ambient temperature test 40°C.

(The manufacturer's reserve the right to alter specifications without prior notification).

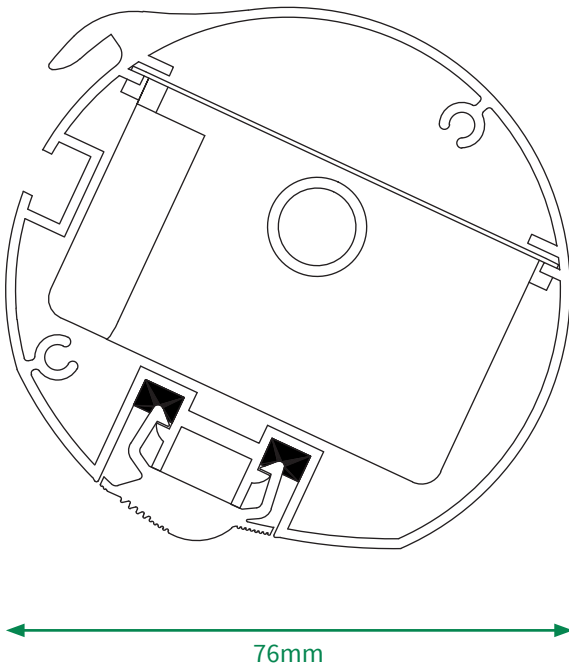

options

Cold or Warm White LED colour.
 RGB RF remote control colour change available on request.
 Non-standard brackets available upon request.
 Standard and non-standard colours.
 Photo electrical cell switches.

brackets

3 pre-set positions enable installer optimum beam angle for sign depth.
 Setting 1 300mm projection 0-2 metre depth.
 Setting 2 500mm projection 2-3 metre depth.
 Setting 3 1000mm projection 3-5 metre depth.

Price will include: Polyester powder coated black or white and 300mm universal brackets.

Telephone: **01922 721 133**
 Facsimile: **01922 659 545**



Portland Lighting
 Unit 2
 Reedswood Park Road
 Walsall
 WS2 8DQ